



DATE: 2018-05-31

MODEL: SR3/8

**STEERING COLUMN CONFIGURATION**

**PRIORITY – LOW (INFORMATION)**

Radical has recently seen examples of non-standard steering system configurations on the SR3 and SR8 models. Radical strongly recommends customers maintain the original standard factory production specification of its cars.

The standard system is as detailed below:

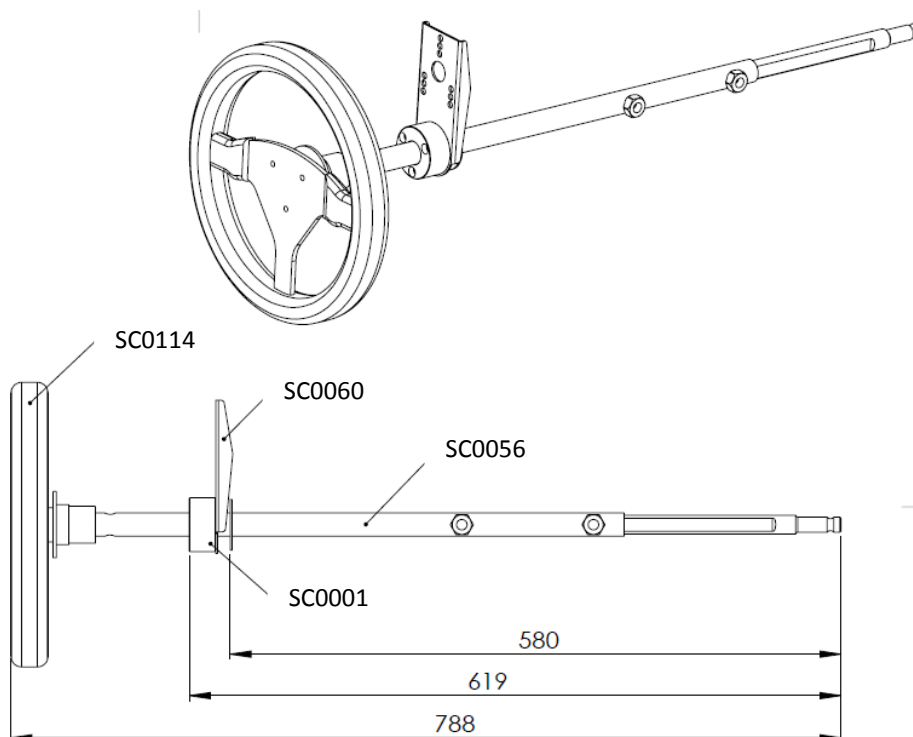

For parts supply please contact: [stores@radicalsportscars.com](mailto:stores@radicalsportscars.com)

Technical Department  
Radical Sportscars

Mobile: +44 (0)7876 146854  
Tel: +44 (0)1733 331616 ext. 263  
Email: [technical@radicalsportscars.com](mailto:technical@radicalsportscars.com)



**RADICAL**

